

## REMEDIATION BY GROUNDWATER AND SOIL AIR CIRCULATION IN SITU USING THE VACUUM-VAPORIZER-WELL (UVB) TECHNOLOGY

W. Bürmann

Institute for Hydromechanics, University of Karlsruhe  
Kaiserstrasse 12, D-7500 Karlsruhe 1, Tel.: (49) 721 6084546

### Abstract

Worldwide, not only in the industrialized countries, the number of known groundwater and soil air contaminations by hydrocarbons, BTX, pesticides, nitrates, etc., increases. Efficient remediation techniques at low costs are needed.

The Vacuum-Vaporizer-Well (UVB) technology (German: Unterdruck-Verdampfer-Brunnen (UVB). Inventor: B. Bernhardt. Patents: IEG mbH, D-7410 Reutlingen) is a new method for the in-situ remediation of groundwater and soil air. Initially developed to clean groundwater contaminated by chlorinated hydrocarbons (CHC), in between this technology is applied also in biological groundwater remediation of pesticides, for example [1,2].

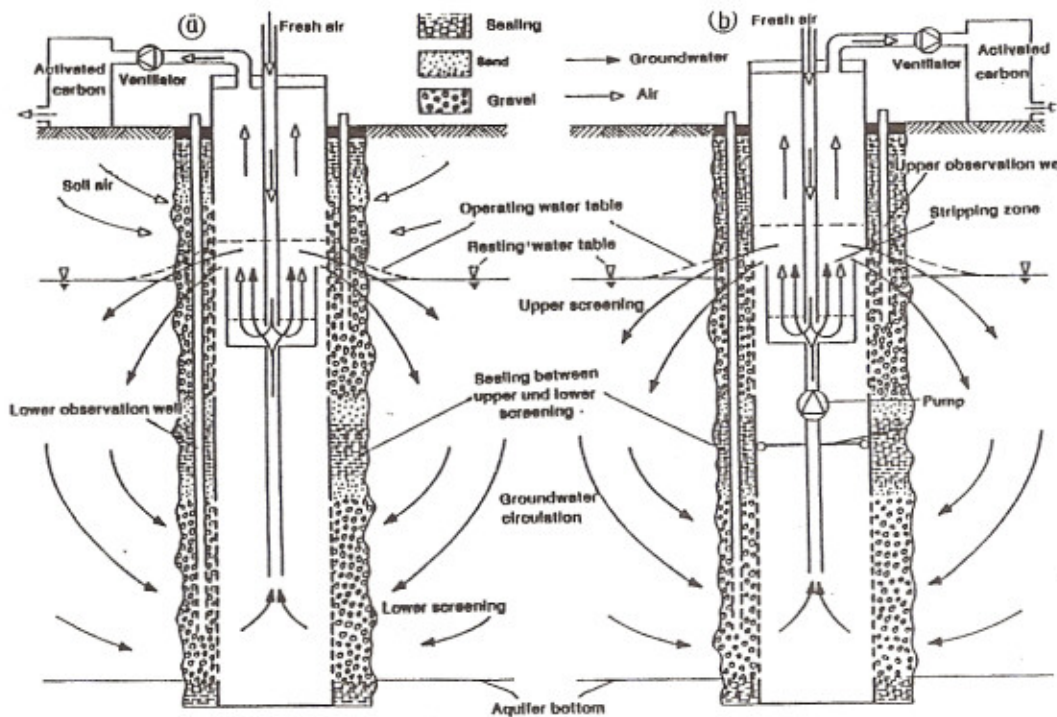

Fig. 1. Typical Vacuum-Vaporizer-Well (UVB) with airlift pump (a) and additional water pump (b)

Some disadvantages of groundwater remediation applying current pumping methods (groundwater lowering, limited yield, insufficient remediation) may be avoided if pumping and recharge take place in the same well. The UVB is an application of this circulation well [3,4,5,6].

Concerning reproduction, photocopying, etc., it is expressly pointed to the copyright.

## Introduction

The UVB produces a circulation flow within the surrounding groundwater, directed from the upper to the lower screening. Figure 1 shows two of various UVB designs. The water is sucked through the lower screening into the well, transported upwards inside the UVB by the air lift pump (figure 1a) which may be supported by an additional water pump (figure 1b). The water is cleaned by fresh air in the stripping zone under below atmospheric pressure, and it is given back through the upper screening without the water leaving the aquifer. Soil air from the unsaturated area of the aquifer may be sucked into the UVB through the upper screening and thus may also be cleaned. The contaminants are adsorbed by activated carbon. If necessary, the groundwater is cleaned on site and led back to the well. To avoid precipitation, the stripping air loop is closed. Thus contaminants which are not adsorbed can be kept from escaping into the atmosphere.

In resting groundwater, the circulation flow creates a permanent flow and consequently cleans the soil within the zone of the well, as all the circulating water flows through the well. Natural groundwater flow which exists in most cases deforms the circulation flow so that a portion of the water flowing towards the intake zone of the well, due to the continual circulation flow, may pass the well several times, whereas the remainder of the water flows through the well only once. Therefore, dimensioning of the cleaning equipment of the UVB must be made so that one flow through the well is sufficient to ensure decontamination of the water.

## Groundwater Flow at the UVB

The circulation flow in moving groundwater shows two separating streamlines, at the bottom and at the top of the aquifer, similar to the perfect well (figure 2). In a well with upward flow, the lower separating streamline corresponds to the withdrawal well and the upper one to the infiltration well. Between these two separating streamlines at the lower and upper boundaries of the aquifer lies the separating stream surface of the flow around the well in the natural groundwater. This surface consists of spacial streamlines and separates between the zone of contaminated and cleaned groundwater in the aquifer.

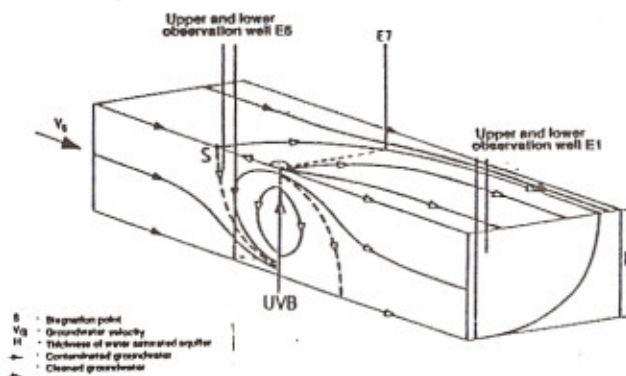

Fig. 2. Typical flow pattern of Vacuum-Vaporizer-Well (UVB) in natural groundwater flow

At the stagnation point S of the UVB (figure 2) the artificial groundwater velocity of the well meets the natural groundwater flow velocity. The dimension of the separating stream surface is characterized by the distance of the stagnation point from the well. As an example for a special case figure 3 shows the water flow rate through the UVB versus the stagnation point distance. In the case of low vertical conductivity (high anisotropy) the stagnation point distance and thus the sphere of influence of the well increase remarkable. The water flow rate through the UVB rises approximately parabolic with the stagnation point distance. Therefore, instead of one well with high water flow rate several small ones with low discharge should be applied.

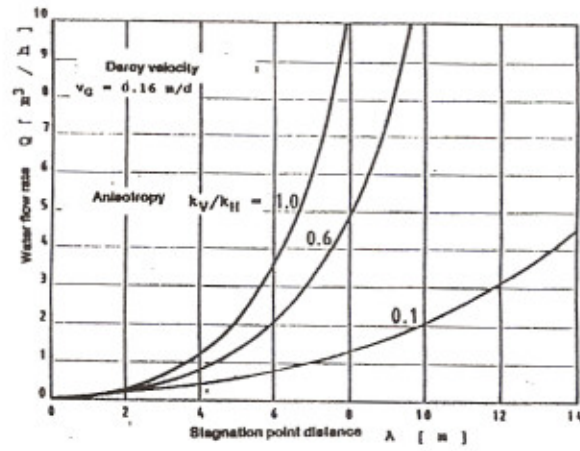

Fig. 3. Water flow rate over stagnation point distance of Vacuum-Vaporizer-Well (UVB) in natural groundwater flow

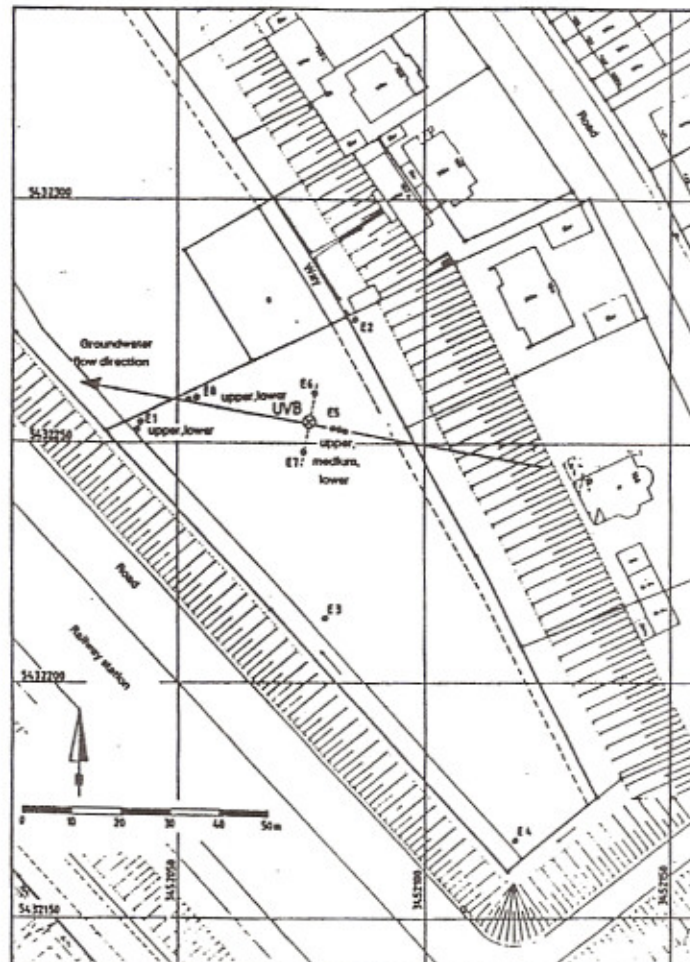

Fig. 4. Karlsruhe Testfield: location of UVB and observation wells

### Physical Groundwater Flow Demonstration Models

Physical desktop aquifer models show the basic flow phenomena of the UVB remediation technology with respect to the natural groundwater flow. These demonstrations include the remediation of an artificial plume containing an impermeable, horizontal lens.

Demonstrations may be accompanied by a real time computer simulation of the fluid flow shown in the model. These computations result from theoretical investigations and base on the mathematical description of the groundwater flow at the UVB using analytical solutions of the governing Laplace partial differential equation.

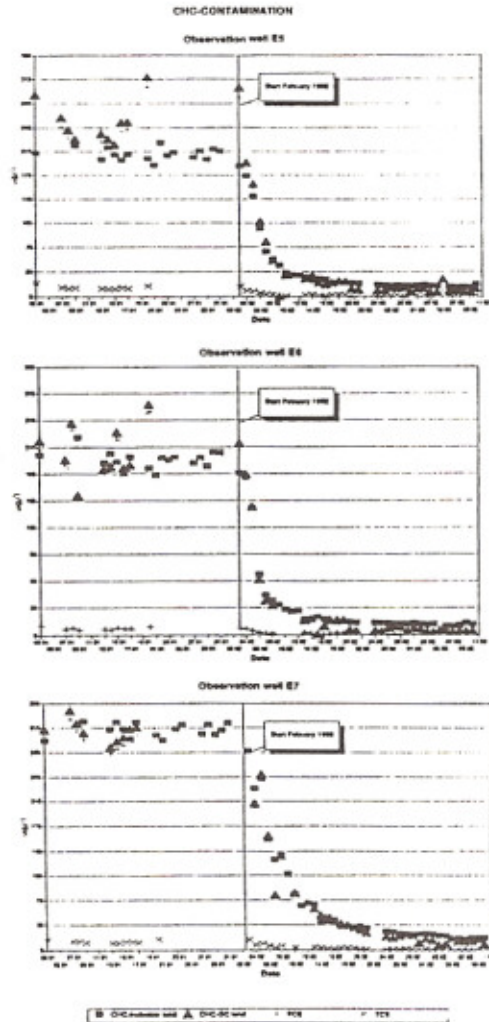
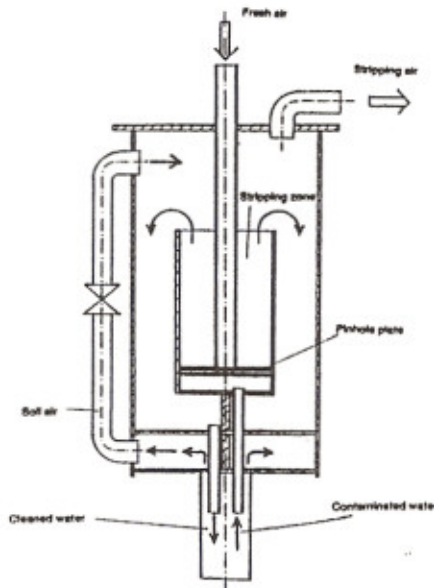

Fig. 5 (left). Karlsruhe Testfield: UVB

Fig. 6 (right). Concentration curve of chlorinated carbons (CHC) at some Karlsruhe Testfield observation wells

### Karlsruhe Testfield

All theoretical investigations are needed for the reliable dimensioning of the UVB. To verify the theory measurements are performed at the UVB in the Karlsruhe Testfield. Figure 4 shows some observation wells close to the UVB some of which appear in Figure 2. The groundwater is contaminated

by chlorinated hydrocarbons (CHC). The properties of the aquifer (geological profiles, pumping tests, groundwater and soil properties, etc.) have been described in some detail [7,8]. With respect to easy operation and low costs the Karlsruhe Testfield UVB in figure 4 is designed different from the UVB of figure 1.

From the manifold of various groundwater investigations (electric conductivity, oxygen content, pH, temperature, etc.) a typical result as an example is chosen. Figure 6 shows the groundwater decontamination at the upstream observation well E5 and at observation wells E6 and E7 besides the UVB. The diagram is based on numerous chemical groundwater analysis by gaschromatograph. Additionally the results of the investigations using a CHC-Indicator are plotted which is using ultraviolet light to decay the CHC [7,8].

#### Acknowledgements

The author gratefully acknowledges IEG mbH, D-7410 Reutlingen, for funding the investigations, and, in particular, B. Bernhardt, IEG mbH, and many others for their work and their numerous helpful discussions and contributions concerning the UVB technology.

#### References

- [1] Bürmann, W., Bott, G., Krug, R.: Groundwater Remediation Using the Vacuum-Vaporizer-Well: Operation of the Well and Biological Remediation of a Groundwater Contamination by Triazine, Proc. 3rd Conference ENVIROTECH VIENNA 1992 (ISEP), April 22-24, 1992, Wien, W. Pillman (Ed.), 1992, 723-732
- [2] Bürmann, W., Wagner, H., Bott-Breuning, G., Rehner, G.: Bodensanierung in situ durch Grundwasserzirkulation mit der Unterdruck-Verdampfer-Brunnen (UVB) Technologie: Prinzip und Sanierungspraxis, M.U.T.-Kongress, October 6-9, 1992, Basel, in press
- [3] Bürmann, W.: Untersuchung der Zirkulationsströmung um den kombinierten Entnahme- und Einleitungsbrunnen zur Grundwassersanierung am Beispiel des Unterdruck-Verdampfer-Brunnens (UVB), Altlastensanierung '90, Dritter Int. KfK/TNO-Kongreß über Altlastensanierung, Karlsruhe, 10.-14. Dezember 1990, in F. Arendt et a. (Ed.), Kluwer Academic Publ., Dordrecht, Boston, London, 1990, 1165-1172
- [4] Buermann, W.: Investigation of the circulation flow around a combined withdrawal and infiltration well for groundwater remediation demonstrated for the Underpressure-Vaporizer-Well (UVB), Contaminated Soil '90, Third Int. KfK/TNO Conference on Contaminated Soil, Karlsruhe, December 10-14, 1990, F. Arendt et a. (Ed.), Kluwer Academic Publ., Dordrecht, Boston, London, 1990, 1045-1052
- [5] Bürmann, W.: Bodensanierung durch Grundwasserzirkulation mit dem Unterdruck-Verdampfer-Brunnen (UVB), Wasserbau-Mitteilungen 36, Institut für Wasserbau, Technische Hochschule Darmstadt, 1991, 93-102
- [6] Herrling, B., Buermann, W., Stamm, J.: In-situ remediation of volatile contaminants in groundwater by a new system of "Vacuum-Vaporizer-Wells (UVB), Subsurface Contamination by Immiscible Fluids, K. U. Weyer (Ed.), A.A. Balkema Publ., Rotterdam, 1991
- [7] Bürmann, W.: Kurzbericht über die Untersuchungen am Unterdruck-Verdampfer-Brunnen (UVB) im Karlsruher Versuchsfeld, Bericht Nr. 680, Institut für Hydromechanik, Universität Karlsruhe, 1992
- [8] Wagner, H.: Hydraulische, hydrogeologische und geologische Untersuchungen im Rahmen des UVB-Forschungsvorhabens, Diplomarbeit, Teil I, Institut für Hydromechanik, gemeinsam mit dem Lehrstuhl für Angewandte Geologie, Universität Karlsruhe, 1992